

## Neptune™ Type 100/300 Series.

Ready Access Distribution Closure For Radial, Through Radial and Maintenance Copper Cable Splicing Applications.



The New Neptune™ Ready Access Closure is quick and easy to install and requires no specialist tooling.

Knockouts in the base section accurately position the cables entering the closure. A variety of cable entry seals are used to manage all cable types ranging from 28mm—4mm cable diameter. Using Dexbond™ sealant provides a very effective method of sealing all cable types both Underground and Overhead in the Access Network.

To ensure the integrity of the closure Installation “Flash Testing” of the joint can be undertaken. Accelerated aging tests have been performed to ensure a minimum life of 25 years service. Closure accessories include a universal mounting bracket for post / pole and wall installations as well as an adaptor plug when utilising a cable bearer bracket in underground chambers. The Neptune™ closure has passed the stringent specification requirements as defined in the British Telecom performance specification LN450B.

## Neptune™ Type 100/300 Series.

### Neptune™ Radial Ready Access Closure

This particular splicing closure has been specifically designed for the splicing of radial cables. The configurations of the cable entries within the base of the closure accurately position each cable entering or exiting the closure. The cable entry seals also provide excellent strain relief and additional cable sheath protection preventing the cable being kinked or damaged when flexed. Cable installation is easy, quick and requires no specialist tooling. Cable knockouts in the base facilitate cable entry. The unique stepped cable entry seals manage cable diameters from 28mm—4mm and can accommodate single or multiple cables to the max diameter indicated. Dexbond™ sealant dispensed in the co-axial cartridge supplied with each closure provides a water / gas tight seal.

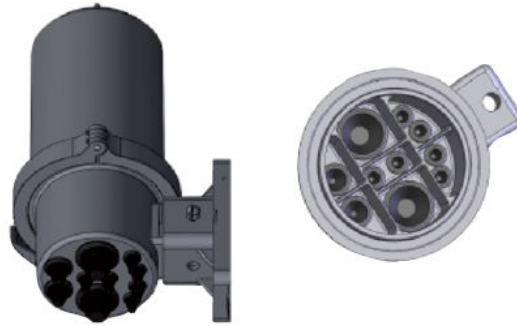

### Neptune™ Through Radial Ready Access Closure

This closure is similar to the radial Ready Access Splicing Closure in its application, however it facilitates a "loop cable" entry. The knockout in the centre section of the base can be pushed out allowing the prepared looped cable to enter through the base opening. A customised rubber plug manages the cables entering the base section. The unique stepped cable entry seals can accommodate single or multiple cables to the maximum diameter indicated. Dexbond™ sealant dispensed in the Co-axial cartridge supplied with each closure provides a water / gas tight seal.

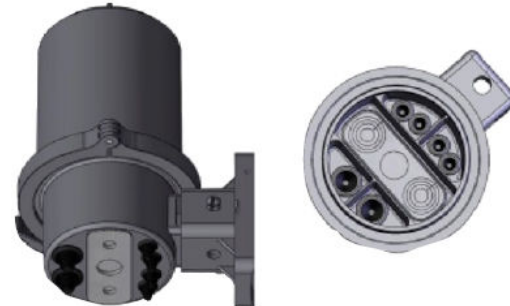

### Neptune™ Maintenance Ready Access Closure

The Maintenance closure has been developed to replace closure systems which are beyond economical repair. The "D" shaped hollow base allows the already terminated cables from the old closure to be passed through the base without taking the services "off-line". A rubber cable entry has a split line to the edge so as each cable can be easily accommodated and positioned in preparation for sealing using the Dexbond™ sealant. Separate compartments allow new drop wires to be installed. Using the unique stepped cable entry seals accommodate single or multiple cables to the max diameter indicated. Dexbond™ sealant dispensed in the Co-axial cartridge supplied with each closure provides a water / gas tight seal.

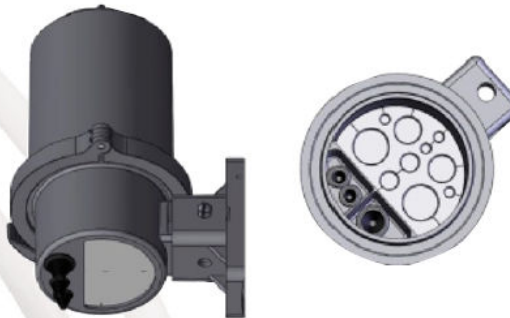

## Neptune™ Type 100/300 Series.

### Dexbond™ Sealant

Dexbond™ is a unique polyurethane sealant for the Telecommunication industry, to ensure joints and cables are effectively sealed against the ingress of water and water vapour. The sealant is dispensed from a hermetically sealed 235ml co-axial cartridge system, once mixed through the mixing nozzle and applied the Dexbond™ sealant is an inert material. Dexbond™ cures inside the 15 minute short term "MEL" permitting the closure to be flash tested to prove the integrity of the installation. The specially developed co-axial cartridge allows greater control over the application of the sealant and reduces sealant wastage as the cartridge can be re-sealed. Dexbond™ is fully compliant to meet the stringent requirement of COSHH.

- Passes BT LN450 Closure Performance Specification
- Passes BT RC9302 Water/Gas Blocking Specification
- Using Specially adapted dome, facilitates flash testing of each closure to ensure pressure tight seal is created
- Fast curing time
- Low curing temperature
- No pre-mixing required
- No cable abrasion required
- Excellent bonding to all communication cable sheath and cable types
- Jointer friendly jointing practice
- Safer to use, no exposure to Isocyanate hardener which is common in other types of resin.
- Non Hazardous material
- No special tooling required
- Re-sealable dispensing cartridges
- No sealant waste



### Installation

The Neptune™ 100 series Ready Access Closure range is very jointer friendly. Training needs are minimal as the design of the closure accommodates the needs of the cable jointer. A simple, quick and very cost effective jointing closure for the Access Network.



Vertical Mounting Position  
(Wall / Wooden Pole)

Horizontal Mounting Position  
(Wall / Wooden Pole)

Mounted to Cable Bearer

## Technical Specifications

### Description

Neptune™ 100 series Ready Access Closure System suitable for copper splicing up to 100pr capacity. Assembly / Disassembly of the dome without any tools. No special tooling required for either cable entry or cable sealing.

### Standard Cable Entries

<b>Radial Closure</b>	6 x Entries 10mm max	Through to	4mm min
	2 x Entries 15.5mm max	Through to	4mm min
	2 x Entries 28.5mm max	Through to	13.5mm min
<b>Through Radial Closure</b>	1 x Entries 18mm max	Through to	4mm min
	4 x Entries 10mm max	Through to	4mm min
	2 x Entries 15.5mm max	Through to	4mm min
	2, Through cables 28.5mm - 13.5mm diameter		
<b>Maintenance Closure</b>	1 x Entries 15mm max	Through to	8mm min
	2 x Entries 10mm max	Through to	6mm min
	1, cable entry adaptor plug		
	(2 x Ø26mm, 2 x Ø20mm, 2 x Ø14, 4 x Ø9mm)		

Note: customised cable entries can be considered.

### Performance Specifications

Reference specification British Telecom LN 450B for Copper Closures used in the Access Network. Testing to other performance requirements can be undertaken by special request.

Title of Test	Requirement	Results	Pass / Fail
Axial Test	No Pressure Loss	No Pressure Loss	Pass
Impact at 23°C	No cracks or pressure loss	No cracks or pressure loss	Pass
Impact at -5°C	No cracks or pressure loss	No cracks or pressure loss	Pass
Static Load at 23°C	No cracks or pressure loss	No cracks or pressure loss	Pass
Static Load at -5°C	No cracks or pressure loss	No cracks or pressure loss	Pass
Torsion	No Pressure Loss	No Pressure Loss	Pass
Static Bend at 23°C	No Pressure Loss	No Pressure Loss	Pass
Flexure at 23°C	No Pressure Loss	No Pressure Loss	Pass
Flexure at -5°C	No Pressure Loss	No Pressure Loss	Pass
Air Tightness	No Pressure Loss	No Pressure Loss	Pass
Temperature Cycling in Air / Water	No Pressure Loss	No Pressure Loss	Pass

### Dexbond™ Sealant

Gas Blocking of Dexbond™ sealant in external joints to BT specification RC9307, Result No Pressure Loss. Temperature cycling in water testing of Dexbond™ sealant to BT specification LN 450B Result No Pressure Loss. Flash testing can commence 15 minutes after sealing application. COSHH compliant.

## Ordering Information

Part Number	Description	Pack Quantity
N100R	Neptune™100 Radial Closure	6
N100TR	Neptune™100 Through Radial Closure	6
N100M	Neptune™100 Maintenance Closure	6
N100SC	Neptune™100 Standard Drill Type	6
N300SC	Neptune™300 Standard Drill Type	6
N300MCS	Neptune™300 Multi-cavity Through Radial Closure	6
N300MCSE	Neptune™300 Multi-cavity Through Radial Closure with extended dome	6
N100U	UMB - Universal Mounting Bracket	6
NAP	Adaptor Plug for Cable Bearer Mounting	6
DEXB01	Co-axial Cartridge 260ml + nozzle	25